



Superconductivity for Electric Systems DOE 2005 Wire Development Workshop

*St. Petersburg, FL
January 19-20, 2005*

HTS Solutions for a New Dimension in Power



Matrix Fault Current Limiter SPI Project Update

Philip J. Pellegrino
President
SuperPower, Inc.

Project Description & Research Integration



Project Goal: Demonstrate MFCL concept at transmission level voltage – 138kV

Project Team:

- SuperPower, Inc.: Program Lead, basic IP for technical approach
- Nexans SuperConductors GmbH: BSCCO-2212 MCP Materials
- American Electric Power (AEP) – Utility Host
- DOE National Labs – CRADA with ORNL on High Voltage Development, CRADAs with LANL and ANL dependent on funding

\$12.2M total cost, with \$6.1M DOE and \$600K EPRI support - DOE Contract Project Period 5/02 to 2/07

Technical Advisory Board:

- Meets 3 – 4 times a year to review program, assess progress, provide technical input
- Utility members: AEP, New York Power Authority, Southern California Edison, Con Edison, Tennessee Valley Authority
- Academia: Rensselaer Polytechnic Institute (RPI)
- Funding sponsors: DOE and EPRI
- National Labs: ORNL, LANL, ANL
- National Electrical Energy Testing, Research And Applications Center (NEETRAC)

Milestone Driven Program



Major Milestone	Objectives	Completion Date
Concept Feasibility & Application Studies	<ul style="list-style-type: none"> • Complete Conceptual Design • Use Technical Advisory Board (TAB) to understand application requirements and perform power system studies 	Completed June 2003
Proof-of-Concept Demonstration	<ul style="list-style-type: none"> • Focus: Scaled hardware non-grid demonstration of matrix concept • Rating: 8kV, 800Arms steady state current, single phase, limit faults up to 25kA asymmetrical 	Completed July 2004
Alpha Prototype	<ul style="list-style-type: none"> • Focus: Scale up for non-grid demonstration at high voltage • Rating: 138kV, application specific current, single phase 	Design by June 2005, Prototype by March 2006
Beta Prototype	<ul style="list-style-type: none"> • Focus: In-grid demonstration for specific utility application • Rating: 138kV, application specific current, three phase 	December 2006

July 2004: Proof-of-Concept Achieved



Voltage VAC	First Peak Current	Avg. First Peak Limiting	Limiting at 3 rd cycle
2400	23.6kA	73.4%	44.4%
2400	27.2kA	68.6%	39.2%
4160	23.4kA	82.6%	52.3%
8660	25.6kA	83.7%	55.9%

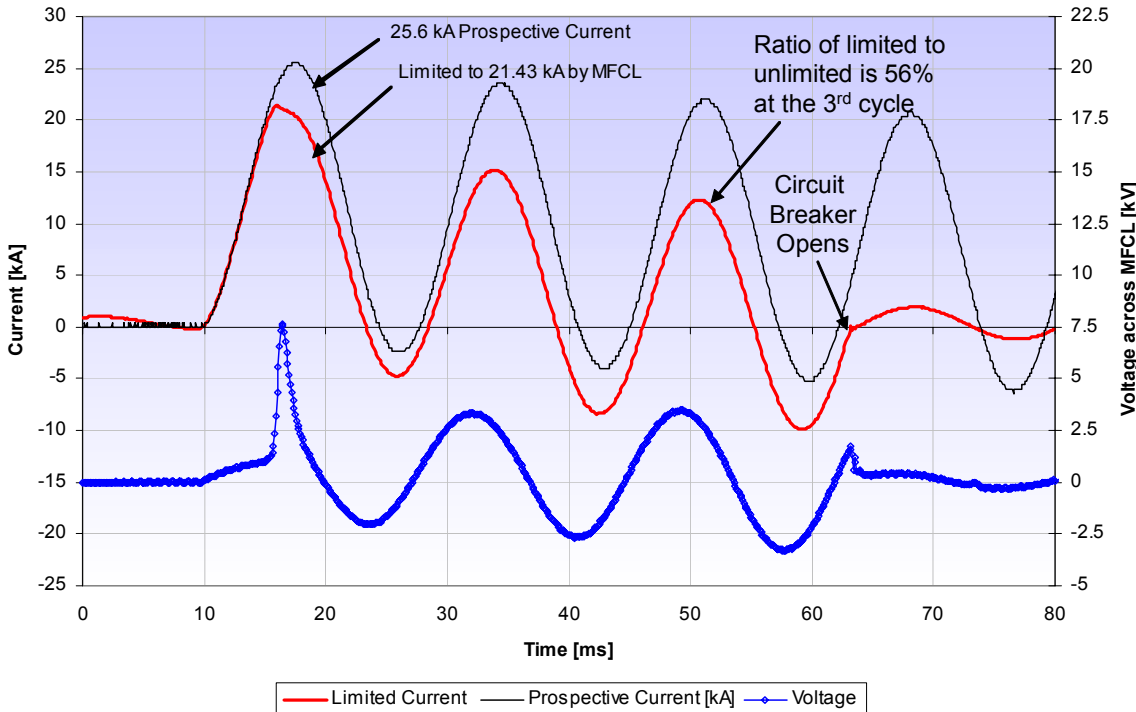

Requirement	Value
Line-to-line voltage	15kV
Line-to ground voltage	8.66kV
Load Current	800Arms
Prospective Fault Current (Asymmetrical)	25kA
Fault Duration	3 cycles
Cryostat Temperature	74K to 77K

AEP Sporn is Target Potential Application for MFCL Beta

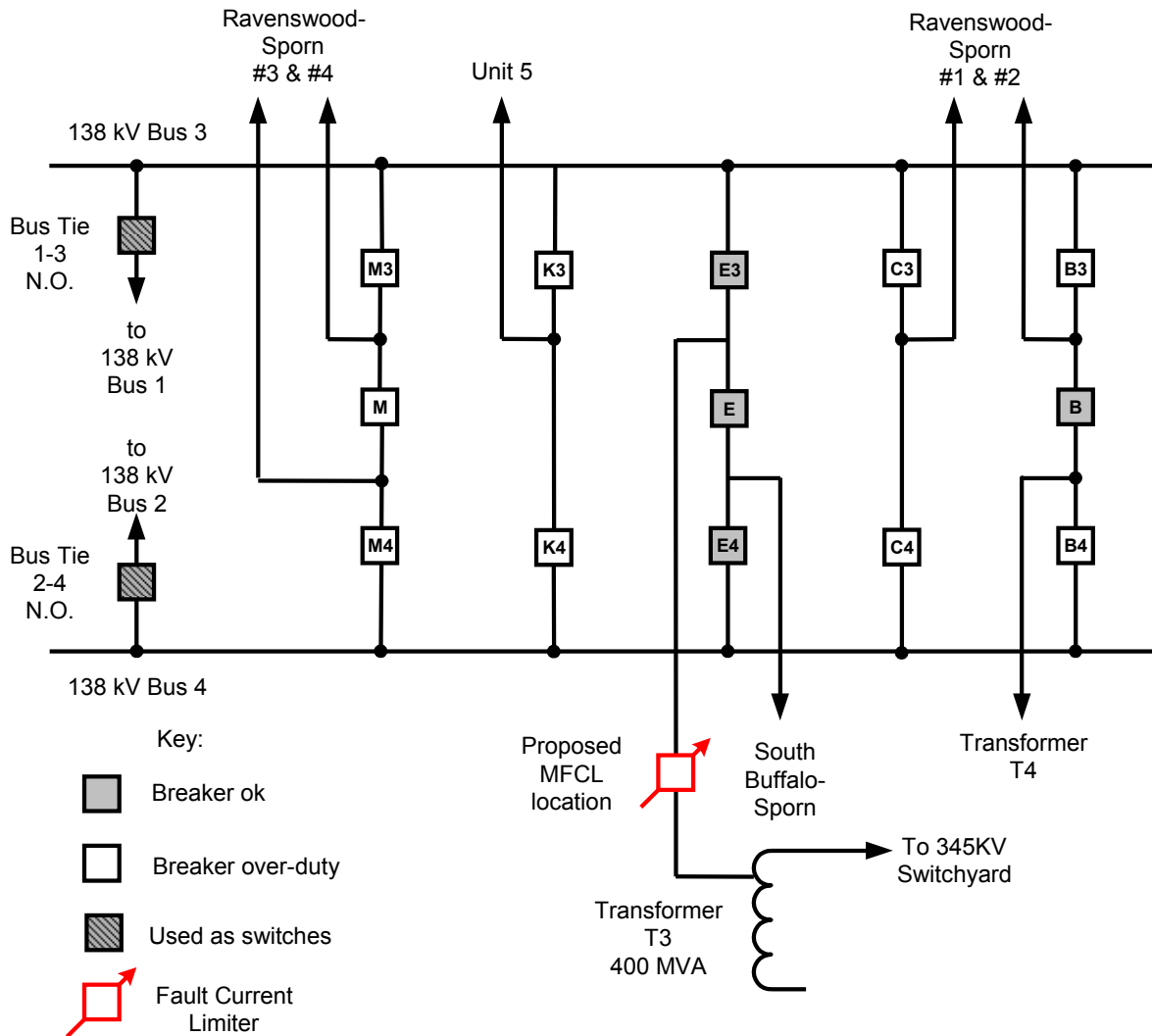

Tie between 345kV switchyard and 138kV switchyard with autotransformer T3

Tie is beneficial during normal operation, but contributes additional 13kA to 138kV bus during faults

Puts 9 breakers (shaded in gray) in an over-duty situation

Problem presently solved with sequential breaker scheme

E and E3 tripped first to remove contribution of T3 to the fault

Alternative solution is to keep T3 connected during fault, but limit current with MFCL

MFCL response can be initially evaluated by leaving sequential trip scheme in place

Alpha Prototype Program Driven by Beta Requirements



Design Alpha prototype to incorporate all the critical Beta requirements and verify those design requirements during the Alpha stage

AEP's role in Alpha Prototype Development:

- AEP System planners to specify:
 - Normal and contingency operating modes: Load current, prospective fault currents and associated current limiting requirements
 - Breaker re-close sequence and Recovery Under Load (RUL) requirements
- Electrical, environmental and reliability test requirements:
 - Specify tests to insure the insulation integrity of the device such as BIL and ac withstand – New types of tests needed due to 'variable' impedance characteristic of MFCL
 - Reliability and maintenance requirements
- Station Designers:
 - Physical constraints on the device for installation in a typical substation
- Protection and Relaying:
 - Impact if device were to fail and backup protection schemes

Alpha Development Main Areas of R&D

HV Development – Scale up to 138kV

- Bushings and Leads
- Cryostat insulation system
- Matrix internal insulation
- Balance with other concerns (thermal, electrical, size, etc.)

Matrix Assembly Design:

- Accommodate more elements
- Scale-up of 'trigger' system

HTS Element Development:

- Continued element performance improvements
- Longer length elements

Cryostat System:

- Higher heat load

System Integration

- Continued simplifications to make assembly and maintenance easier
- Instrumentation and monitoring

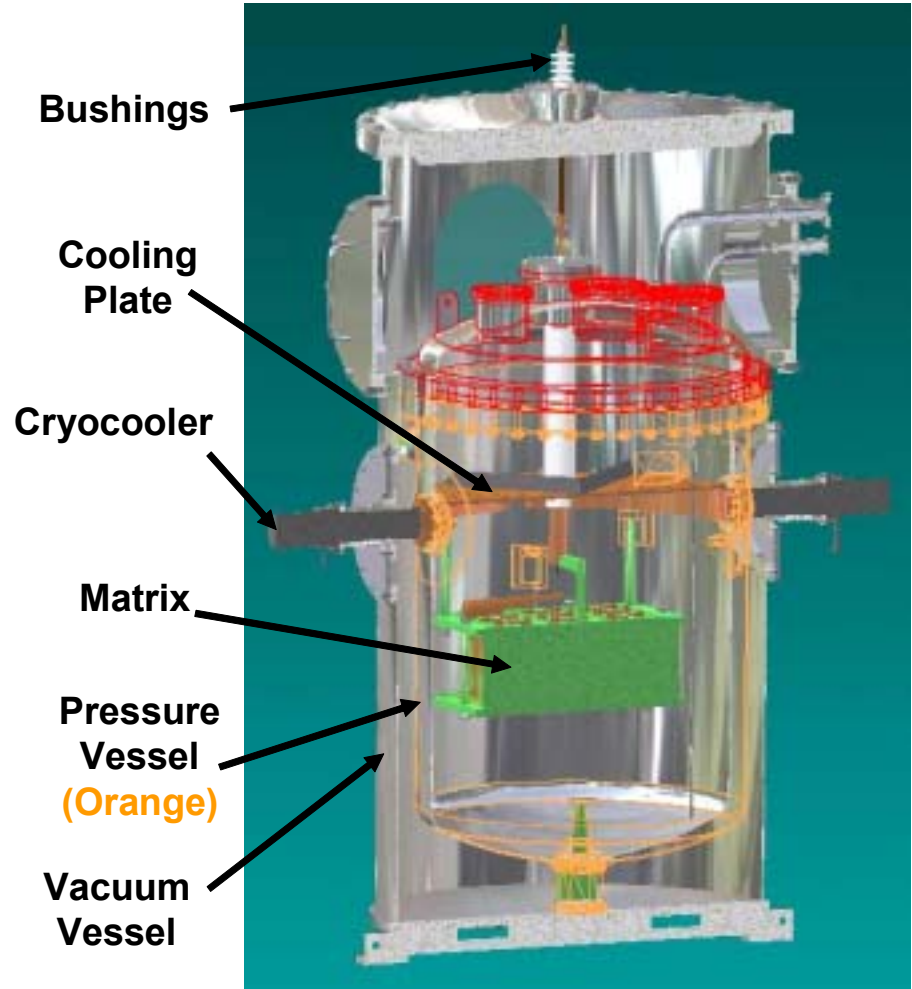

Main Components for the Pre-Prototype

MFCL Alpha High Voltage Development Progress



Activity	Objectives	Status
<p>High voltage and cryogenic environment studies</p> <p>Will support matrix and cryostat insulation system design</p>	<p>Basic characterization of insulation properties (AC withstand, impulse, Partial Discharge) of LN₂ (stagnant and boiled), GN₂, dielectric materials such as G10; Effects of pressure</p> <p>Develop transfer function between tests and FEA results</p> <p>Conduct experiments up to 200kV ac withstand and 750kV impulse (some margin above 650kV)</p>	<p>Completed initial experiments on mock-ups at ORNL using basic geometries</p> <p>Transfer functions being developed to predict breakdown voltages for the range of voltage, gap and electrode geometries tested</p> <p>Tests conducted up to 100kV AC, 340kV impulse at ORNL</p>
<p>Bushings and Leads</p>	<p>Preferred Approach - Investigate use of custom-designed bushing for MFCL application</p> <p>Back-up - Qualify candidate commercial bushings for cryogenic applications</p>	<p>Completed initial investigations on custom bushing for Alpha prototype</p> <p>Completed qualification of insulating materials of two commercial bushings at ORNL</p>
<p>Develop test standards</p>	<p>Agree with AEP and greater utility community on AC withstand, BIL test methods for MFCL</p>	<p>Initial discussions with AEP complete, agreements still pending</p>

MFCL Alpha High Voltage Development Progress



Testing Cryogenic Performance of Bushing Insulating Materials at ORNL



One Geometry For Testing at ORNL: Sphere - Plane

MFCL Alpha HTS Element Development Progress



20cm Element Used on Pre-Prototype

General Objectives:

- Low I^2R losses and optimized dimensions
- Robustness by mechanical stabilization to provide a 30 year device lifetime
- Low AC losses in the HTS
- Small contact resistance between HTS and Copper
- Minimized losses between the elements (connectors)
- Long length single tubes up to 30cm
- Even longer elements by connecting two tubes directly together (saving a connector)
- High E-Fields through optimized normal state resistivity

MFCL Alpha HTS Element Development Progress



Material Improvements

	June 2004	Oct 2004
Critical Current	1500 A	1800 A
Critical Current Density	1280 A/cm²	1500 A/cm²
Jc Uniformity	~ 7%	~ 4%
RT Resistivity	3 mΩcm	2.8 mΩcm

From June 2004 to Oct 2004:

- Improved the mechanical design with improved stabilization and connectors
- Improved production methods leading to higher uniformity from batch to batch
- Increased critical current density to reduce material needs and lowers losses
- Higher normal state resistivity lowers first peak current
- High nominal currents in single tube

MFCL Alpha Matrix Assembly Progress



Activity	Objectives	Status
Employ improved elements	Characterize new HTS element designs, by applying repeated pre-determined high short-circuit current for different pre-determined durations	Testing initiated at KEMA PowerTest
Scale up MFCL matrix “trigger” circuit for more elements	Characterize new trigger designs by applying repeated pre-determined high short-circuit current for different pre-determined durations	Scaled mock-ups implementing new trigger design built – To be tested at KEMA
Characterize recovery of HTS elements	Characterize HTS element thermal recovery under no-load current and recovery under load	Load banks for tests purchased – To be tested at KEMA

Matrix-type fault current limiter

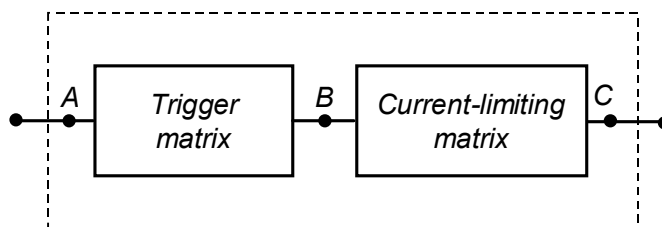

MFCL Alpha Cryostat Progress



Alpha cryostat design will build on the successful design used in the proof-of-concept pre-prototype

No major design changes anticipated other than:

- Elimination of vacuum dielectric space for high voltage leads
- Address higher heat load

Objective: Use a small test cryostat optimized to study the following:

- Further studies on the stability the sub-cooled and pressurized operating condition
- Study controllability of the environment for normal state and recovery after the fault

Status: Will complete assembly of small cryostat in early Feb. to begin studies



Successful Pre-Prototype Cryostat

Summary



Progressing on target for 2007 commercialization

Continued favorable market pull for transmission-level FCLs:

- Accommodate increasing fault currents due to added generation
- Avoid adverse side effects imposed by existing solutions
- Prevent breaker failures and other problems (breaker failure, welded contacts, bus bracing, etc.)
- Reduce “through fault” stresses on aging infrastructure – First peak current limitation
- Maintain flexibility to accommodate load growth and “open access”
- Avoid need for expensive 80kA breakers